



***Facility Study
For
Generation Interconnection
Request
GEN-2005-012***

SPP Tariff Studies

(#GEN-2005-012)

November 2007

Executive Summary

<OMITTED TEXT> (Customer) has requested a Facility Study under the Southwest Power Pool Open Access Transmission Tariff (OATT) for interconnection of a 400 MW wind powered generation facility in Ford County, Kansas to the transmission system of Sunflower Electric Power Corporation (SUNC). The wind powered generation facility was studied with two hundred (200) individual Gamesa G87 2.0 MW wind turbines.

The generation facility was studied to interconnect into the SUNC Spearville 345kV substation bus. The Feasibility and Impact Studies were conducted on this assumption with all Expansion Planning projects in service in the Spearville area. The facilities necessary for interconnecting the wind farm include the addition of a 345kV terminal at Spearville substation, which will include adding two 345kV breakers into the breaker-and-a-half bus configuration. The estimated cost of the terminal addition is \$2,904,000.

During the process of conducting the Facility Study Mid Kansas Electric Company (MKEC) has postponed indefinitely certain Expansion Planning projects in the Spearville area. These projects included a second 230/115kV autotransformer and a second 115kV line from Spearville to the Dodge City area. Also, changes have occurred in a previous queued project in the Spearville area. Because of these topology changes, the Impact Stability study was performed again to determine the reactive compensation requirements of the wind farm.

The results of the Impact Study have determined that the Gamesa turbines will trip off for a fault that causes the outage of the Spearville 345/230 kV autotransformer as well as an outage of the Spearville – Holcomb 345kV transmission line. It was found that the addition of a STATCOM was not sufficient to maintain a stable transmission system. It was found that the construction of a 345kV transmission line would be necessary to keep the full 400 MW wind farm on line for these outages. The cost of the proposed Spearville-Wichita 345kV line is approximately \$160,000,000. As this was considered cost prohibitive to the Customer, analysis was conducted assuming that two (2) STATCOMs no larger than +/-8MVA would be installed for this wind farm request. The recommendation is to lower the queue position to 330 MW. For this generation amount, the wind farm will require the addition of two (2) 34.5kV, +/-8 MVA STATCOM devices on the Customer's 34.5kV bus. The Interconnection Customer will also be required to install 60 Mvar of 34.5kV capacitors.

If the Customer wishes to pursue the option of building the 345kV transmission line from Spearville to Mooreland, Customer should advise SPP of this decision for a more detailed estimate of costs. Otherwise, the queue position will be lowered to 330MW.

Once a decision is made between lowering the queue position and building the 345kV line, a final Facility Study can be issued if necessary to be used in the LGIA.

Changes that occur to higher queued projects in the queue will require a restudy of this generation interconnection request.

1 Introduction

<OMITTED TEXT> (Customer) has requested a Facility Study under the Southwest Power Pool Open Access Transmission Tariff (OATT) for interconnection of a 400 MW wind powered generation facility in Ford County, Kansas to the transmission system of Sunflower Electric Power Corporation (SUNC). The wind powered generation facility was studied with two hundred (200) individual Gamesa G87 2.0 MW wind turbines.

The Impact Study has also been conducted again in part due to a change to the transmission system topology.

2 Project Location and Existing Facilities

The project is located in Ford County, Kansas, a few miles southeast of the Spearville 345/230/115kV substation.

The Customer requested an interconnection point of the Spearville 345kV substation, which is owned by Sunflower Electric Power Corporation

3 Interconnection Facilities

3.1 Spearville 345kV Terminal - The Customer will be interconnecting into the Spearville 345kV substation owned by Sunflower. The Customer will build a 345kV radial line from their wind farm facilities to the Spearville substation. A 345kV breaker-and-a-half terminal will be added for the wind farm.

The costs for the substation work at Spearville is estimated below:

- Installing 345kV line terminal including two (2) 345kV circuit breakers, four (4) 345kV disconnect switches and associated structural steel, foundations, and associated equipment

Subtotal	\$2,903,000
-----------------	--------------------

3.2 Spearville-Wichita 345kV Line - Approximate 160 miles of 345kV transmission line from Spearville – Wichita substations which is necessary for full 400MW of interconnection service. Approximate cost is \$160,000,000. This is not a detailed estimate. Customer should advise if it wishes to study this option further.

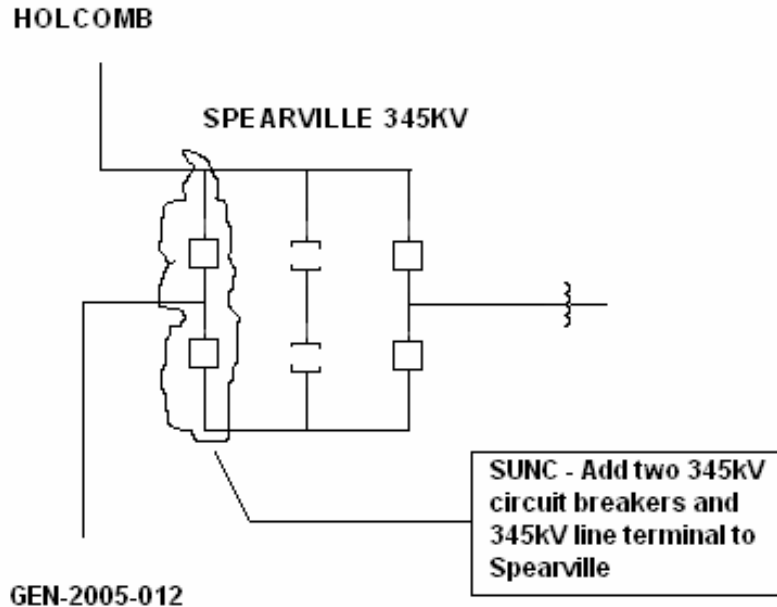

Figure 1. Interconnection Configuration

3.3 Customer Facilities

3.3.1 34.5kV Capacitor Bank – The Customer will be required to install 60 Mvar of 34.5kV capacitors spread across the two 345/34.5kV Customer transformers. Each capacitor bank shall be composed of at least three stages of 10 Mvar each or other industry accepted size.

3.3.2 Statcom Devices – To comply with FERC Order 661A low voltage ride through requirements, the Customer will be required to install two (2) 34.5kV, +/- 8MVA STATCOM devices in the Customer substation on the 34.5kV buses of the Customer substation. These devices will prevent the tripping of the Gamesa turbines for the outage of the Spearville 345/230kV transformer and will prevent possible voltage collapse for the outage of the Spearville – Holcomb 345kV line.

4 Short Circuit Analysis

Sunflower Electric conducted a short circuit analysis for the addition of the 400 MW generation addition. No equipment was found to exceed its fault interrupting duty with the addition of GEN-2005-012.

5 Stability Analysis

5.1 Objective

The objective of the stability study is to determine the impact on system stability of connecting the proposed GEN-2005-012 wind farm to SPP's transmission system.

5.2 The Wind Generating Facility

The rated output of the generation facility is 400MW, comprised of two hundred (200) Gamesa G87 wind turbines. The base voltage of the Gamesa turbine is 690 V, and a generator step up transformer (GSU) of 2500kVA connects each unit to the high side of 34.5kV. The rated power output of each turbine is 2.0 MW while the actual power output depends on the wind. In performing a system impact study, the wind farm generation from the study customer and previously queued customers is dispatched into the SPP footprint.

The Customer's substation will contain two 345/34.5kV, 105/140/175 MVA transformer and appropriate 345kV and 34.5kV switching equipment. The Customer substation will contain 60 Mvar of 34.5kV capacitors and a two 34.5kV, +/-8MVA STATCOM devices.

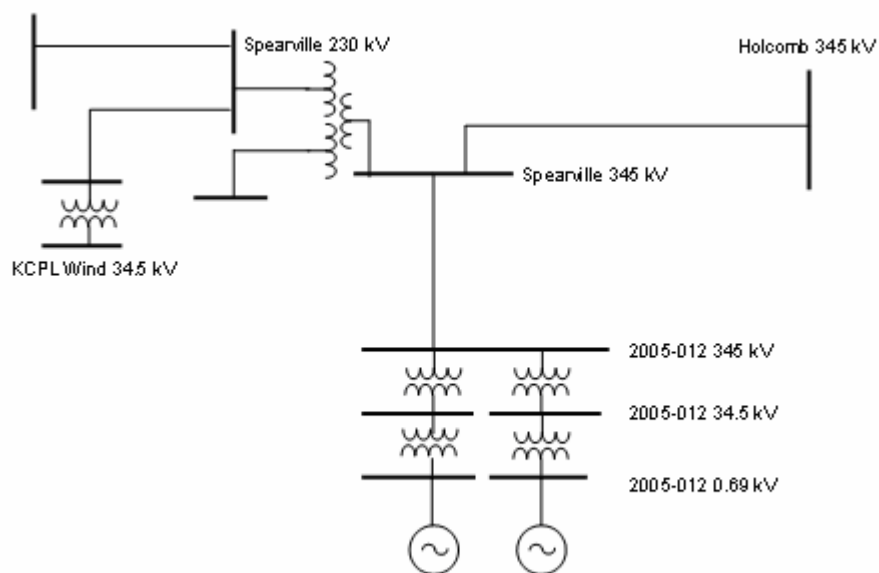

In addition to the base cases and interconnection configuration, the Customer provided the Project data consisting of generating units and their generating step-up transformers. In order to simplify the model of the wind farm, the wind turbines were aggregated in such a manner as to have one equivalent unit for several turbines connected to the same 34.5kV feeder end point.

In order to have unity power factor at the POI (Spearville 345 kV), two 30 MVAR capacitor banks are required. This assumes two step-up transformers 34.5/345 kV each with 10% reactance on 105 MVA base. The capacitor banks are located at 34.5 kV bus of each transformer.

The load-flow cases and dynamic library included prior queued projects. These projects are:

- a. Gray County Wind Farm -110 MW consisting of (167) Vestas V47 turbines.
- b. GEN-2001-039A – 115kV Wind Farm – 105 MW consisting of Clipper wind turbines.
- c. GEN-2002-025A – Spearville 230kV Wind Farm – 150 MW wind farm consisting of (100) GE turbines.
- d. GEN-2004-014 – Spearville 230kV Wind Farm – 154.5 MW wind farm consisting of one-hundred-three (103) GE turbines.

The wind farm was modeled with Gamesa G87 2.0 MW wind turbine generators (WTG). The parameters for the Gamesa wind turbines are given in Table 4. The WTG model was comprised of several user models for dynamic simulation as follows:

1. Doubly-fed induction generator model including provision for rotor control,
2. Active rotor control model (representation of rotor converter circuit)
3. Pitch angle control model
4. Wind model allowing wind gusts and ramps to be applied,
5. 2-mass shaft model to represent the effects of the rotor/hub connected via a 'flexible' shaft to the generator,
6. Aerodynamic model which calculates the aerodynamic torque applied to the rotor taking into account wind speed, tip speed ratio Λ , performance coefficient etc.,
7. Model to read the turbine Cp matrix,
8. Under/over frequency generator tripping relay.
9. Under/over voltage generator tripping relay.

In the power flow, equivalent WTGs and generator step-up (GSU) transformers were used to represent the detailed distribution of individual WTGs. In addition, dynamic data for the wind turbines and the different models listed above, plus the voltage/frequency protection components were added to the dynamics database. Since the proposed WTGs have ride-through capability for voltage and frequency, detailed relay settings for voltage/frequency protection schemes were included in the model.

The protection models for under/over frequency and under/over voltage models were located at the generator bus to which the WTG equivalents were connected. These models monitor the frequency/voltage on that bus over the course of a simulation period. The current standard ride-through capability available is reflected in the Gamesa wind turbine model package as shown in Table 2 and Table 3 for frequency and voltage, respectively. These standard settings were used in the study.

Table 2: Over/Under Frequency Relay Settings for Gamesa WTG

Frequency Settings in Hertz	Time Delay in Seconds	Breaker time in Seconds
$62 \leq F \leq 57$	0.0	0.05

Table 3. Over/Under Voltage Relay Settings for Gamesa WTG

Voltage Settings Per Unit	Time Delay in Seconds	Breaker time in Seconds
$V \leq 0.15$	0.04	0.05
$0.15 < V \leq 0.3$	0.625	0.05
$0.30 < V \leq 0.45$	1.10	0.05
$0.45 < V \leq 0.65$	1.575	0.05
$0.65 < V \leq 0.75$	2.05	0.05
$0.75 < V \leq 0.90$	2.55	0.05
$V \geq 1.1$	0.06	0.05

The following assumptions were adopted for the study:

1. A constant maximum and uniform wind speed was considered during the entire period of study.
2. The WTG control models were used with their default values.
3. The settings for the under/over voltage/frequency were set according to the standard manufacturer data.

Table 4. Gamesa G87 2.0 MW Wind Generator Data

Parameter	Value
BASE KV	0.690
WTG MBASE	2.00
TRANSFORMER MBASE	2.50
TRANSFORMER R ON TRANSFORMER BASE	0.006
TRANSFORMER X ON TRANSFORMER BASE	0.060
GTAP	1.00
PMAX (MW)	2.0
PMIN	0.0
RA	0.01022
LA	0.14283
LM Delta	7.21137
LM Y	6.94532
RMACH	0.01008
L1	0.17503

5.3 Contingencies Simulated

Nineteen (19) faults were considered for the transient stability simulations which included three phase faults, as well as single phase line faults, at the locations defined by SPP. Single-phase line faults were simulated by applying a fault impedance to the positive sequence network at the fault location to represent the effect of the negative and zero sequence networks on the positive sequence network. The fault impedance was computed to give a positive sequence voltage

at the specified fault location of approximately 60% of pre-fault voltage. This method is in agreement with SPP current practice. Table 5 shows the list of simulated contingencies. The table also shows the fault clearing time and the time delay before re-closing for all the study contingencies.

Table 5. List of the Simulated Faults

Cont. No.	Cont. Name	Description
1	FLT13PH	3 phase fault on the Spearville (56469) to Holcomb (56449) 345 kV line, near Spearville. a. Apply fault at the Spearville bus (56469). b. Clear fault after 5 cycles by tripping the line from Spearville (56469) to Holcomb (56449). c. Wait 20 cycles, and then re-close the line in (b) back into the fault. d. Leave fault on for 5 cycles, then trip the line in (b) and remove fault.
2	FLT21PH	<i>Single phase fault and sequence like Cont. No. 1</i>
3	FLT33PH	3 phase fault on the Spearville (58795) to Mullergren (58779) 230 kV line, near Spearville. a. Apply fault at the Spearville bus (58795). b. Clear fault after 5 cycles by tripping the line from Spearville (58795) to Mullergren (58779). c. Wait 20 cycles, and then re-close the line in (b) back into the fault. d. Leave fault on for 5 cycles, then trip the line in (b) and remove fault.
4	FLT41PH	<i>Single phase fault and sequence like Cont. No. 3</i>
5	FLT53PH	3 phase fault on the Spearville 345kV bus a. Apply fault at the Spearville bus. b. Clear fault after 5 cycles by tripping the Spearville 345/230kV autotransformer from service.
6	FLT61PH	<i>Single phase fault and sequence like Cont. No. 5</i>
7	FLT73PH	3 phase fault on the Greensburg (58764) to Sun City (58797) 115 kV line, near Greensburg. a. Apply fault at Greenburg. b. Clear fault after 5 cycles by tripping the line from Sun City - Greenburg c. Wait 20 cycles, and then re-close the line in (b) back into the fault. d. Leave fault on for 5 cycles, then trip the line in (b) and remove fault.
8	FLT81PH	<i>Single phase fault and sequence like Cont. No. 1</i>
9	F09-3PH	3-phase fault at Mullergren on 230 kV line to Spearville <u>Time</u> <u>Fault Clearing</u> 5 Trip breaker at Mullergren for line 58779[MULGREN6] - 58795[SPEARVL6] 7 Clear fault
10	F10-SLG	SLG fault at Mullergren on 230 kV line to Spearville, Breaker failure at Mullergren, [CB6012] <u>Time</u> <u>Fault Clearing</u> 7 Trip breaker at Spearville for line [MULGREN6] - 58795[SPEARVL6] 16 Trip line 58779[MULGREN6]-56871[CIRCLE6] Clear fault
11	F11-3PH	3-phase fault at Spearville on 230 kV line to Mullergren <u>Time</u> <u>Fault Clearing</u> 5 Trip breaker at Spearville for line 58779[MULGREN6] -[SPEARVL6] 7 Clear fault
12	F12-SLG	SLG fault at Spearville on 230 kV line to Mullergren, Breaker failure at Mullergren, [CB6012]

Cont. No.	Cont. Name	Description
		<u>Time</u> <u>Fault Clearing</u> 5 Trip breaker at Spearville for line 58795[SPEARVL6]-[MULGREN6] 16 Trip line 58779[MULGREN6]-56871[CIRCLE6] Clear fault
13	F13-3PH	3-phase fault at North Judson Large on 115 kV line to Spearville <u>Time</u> <u>Fault Clearing</u> 7 Trip breaker at North Judson Large for line 58871[NOR-JUD3] - SVL3] 9 Clear fault
14	F14-SLG	SLG fault at North Judson Large on 115 kV line to Spearville Breaker failure at North Judson Large, [CB3071] <u>Time</u> <u>Fault Clearing</u> 9 Trip breaker at Spearville for line 58871[NOR-JUD3]----- -----58794[SPEARVL3] 20 Trip line 58871[NOR-JUD3] -58771[JUD-LRG3] Trip line 58767[HAGGARD3]-58799[W-DODGE3] Clear fault
15	F15-3PH	3-phase fault at Judson Large on 115 kV line to GEN-2001-039A Tap <u>Time</u> <u>Fault Clearing</u> 7 Trip breaker at Judson Large for line 58771[JUD-LRG3] ----- -----103[SSTAR_4] 9 Clear fault
16	F16-SLG	Place Holder – no fault
17	F17-3PH	3-phase fault at GEN-2001-039A on 115 kV line to Greensburg <u>Time</u> <u>Fault Clearing</u> 7 Trip breaker at Clipper Tap for line 103[SSTAR_4]-58764[GRNBURG3] 9 Clear fault
18	F18-SLG	SLG fault at GEN-2001-039A on 115 kV line to Greensburg Breaker failure at Medicine Lodge, [CB3102] <u>Time</u> <u>Fault Clearing</u> 7 Trip breaker at Clipper Tap for line 103[SSTAR_4]-58764[GRNBURG3] 20 Trip line 58773[MED-LDG3] -58797[SUNCITY3] Clear fault
19	FLT19	Open 345kV line from Spearville (#56469)-Holcomb(#56447)with no fault
20	FLT20	Open 230kV line from Spearville (#58795)-Mullergren(#58779) with no fault

5.4 Results

Simulations were performed with a 0.1-second steady-state run followed by the appropriate disturbance as described in Table 5. Simulations were run for a minimum 10-second duration to confirm proper machine damping.

The simulation results showed that the wind farm and prior queued projects trip off for several of the simulated faults. An unstable system was observed for the opening of the Holcomb – Spearville 345kV line.

A SVC device was added at the 345kV bus of the wind farm, but did not alleviate the trips or instability. The generation at the wind farm was reduced to 354 MW and found that the project would stay on line with two +/- 8 MVA STATCOM

devices, but two prior queued projects would trip off for the outage of the Spearville – Holcomb 345kV line and Spearville 345/230kV transformer.

To verify system stability at 354 MW, the simulations were rerun disabling the low voltage tripping of the prior queued project. The result was an unstable system. The Spearville area was shown to experience voltage collapse for an outage of the Spearville - Holcomb 345kV line (FLT19).

Rather than raise the size of the STATCOM devices, the generation level was further reduced to 330 MW. With unity power factor at the high side of the substation transformers and two +/- 8 MVA STATCOM devices, the wind farm stayed on line and the transmission system remained stable for all simulated faults.

The transmission system was tested with the proposed Spearville – Wichita 345kV transmission line in service. With the line in service, the system is stable for all 400MW of Customer generation.

Results are summarized in Table 6.

Table 6. Results of Simulations

Cont. No.	Cont. Name	WP	WP	WP	WP	WP	WP	WP	SP	SP
		400 MW	400 MW (PQ tripping disabled)	354 MW with +/- 8MVA STATCOM (PQ tripping disabled)	330 MW (PQ tripping disabled)	330 MW with +/- 8 MVA STATCOM	330 MW with +/- 8 MVA STATCOM (PQ tripping disabled)	400MW with 345kV Line	330 MW with +/-8 MVA STATCOM (PQ tripping disabled)	400MW with 345kV Line
1	FLT13PH	PQ project Tripping	UNSTABLE	UNSTABLE	UNSTABLE	PQ project Tripping	Stable	Stable	Stable	Stable
2	FLT21PH	PQ project Tripping	UNSTABLE	UNSTABLE	UNSTABLE	PQ project Tripping	Stable	Stable	Stable	Stable
3	FLT33PH	PQ project Tripping				PQ project Tripping	Stable	Stable	Stable	Stable
4	FLT41PH	PQ project Tripping				PQ project Tripping	Stable	Stable	Stable	Stable
5	FLT53PH	PQ project Tripping				PQ project Tripping	Stable	Stable	Stable	Stable
6	FLT61PH	Stable				Stable	Stable	Stable	Stable	Stable
7	FLT73PH	Stable				Stable	Stable	Stable	Stable	Stable
8	FLT81PH	Stable				Stable	Stable	Stable	Stable	Stable
9	F09-3PH	PQ project Tripping				PQ project Tripping	Stable	Stable	Stable	Stable
10	F10-SLG	Stable				Stable	Stable	Stable	Stable	Stable
11	F11-3PH	PQ project Tripping				PQ project Tripping	Stable	Stable	Stable	Stable
12	F12-SLG	PQ project Tripping				PQ project Tripping	Stable	Stable	Stable	Stable
13	F13-3PH	PQ project Tripping				PQ project Tripping	Stable	Stable	Stable	Stable
14	F14-SLG	PQ project Tripping				PQ project Tripping	Stable	Stable	Stable	Stable
15	F15-3PH	PQ project Tripping				PQ project Tripping	Stable	Stable	Stable	Stable
17	F17-3PH	PQ project Tripping				PQ project Tripping	Stable	Stable	Stable	Stable
18	F18-SLG	Stable				Stable	Stable	Stable	Stable	Stable
19	FLT19	UNSTABLE	UNSTABLE	UNSTABLE	UNSTABLE	PQ project Tripping	Stable	Stable	Stable	Stable
20	FLT20	Stable				Stable	Stable	Stable	Stable	Stable

6 Conclusion

The GEN-2005-012 generation interconnection request for 400W cannot be interconnected at 400MW without the construction of major new transmission. GEN-2005-012 may be interconnected into the SPP transmission system at 330 MW. The cost of interconnection facilities on the Sunflower Electric Power Corp. transmission system will cost approximately \$2,904,000.

The Customer may interconnect the full 400MW by pursuing the option of building the 345kV line from Spearville – Wichita. The approximate cost of this line is \$160,000,000.

The Interconnection Customer will be required to install two (2) 34.5kV, +/- 8 MVA STATCOM devices on the 34.5kV buses of their substation transformers. The Interconnection Customer will be required to install two (2) 34.5kV, 30 Mvar capacitor banks in their substation for a total of 60 Mvar. These capacitor banks shall contain at least three stages of industry accepted sizes.